

Summer 2015

CBRNE Task Forces

James B. Burton

Fred J Burpo
john.burpo@westpoint.edu

Elmore F. Smoak



Recommended Citation

Burton, James B.; Burpo, Fred J; and Smoak, Elmore F., "CBRNE Task Forces" (2015).

CBRNE Task Forces



*By Brigadier General J. B. Burton, Colonel F. John Burpo, and
Lieutenant Colonel Elmore F. Smoak (Retired)*

Since the advent of modern warfare, commanders have applied a combined arms strategy to overmatch adversary capabilities and to generate decisive advantages at key points on the battlefield. Formed from mounted and dismounted maneuver units—and with artillery and aviation support—the overwhelming, integrated combined arms entities complement one another. Similarly, today’s chemical, biological, radiological, nuclear, and explosives (CBRNE) units must be capable of being employed as integrated formations to capitalize on their overlapping and synergistic strengths and to provide supported commanders with the capacity to effectively and decisively operate in an environment that is complicated by CBRNE hazards. This article describes the evolution of the 20th CBRNE Command from a functional force provider of chemical, biological, radiological, and nuclear (CBRN) and explosive ordnance disposal (EOD) capabilities to one that scales, tailors, and employs multifunctional CBRNE task forces to meet the full range of CBRNE threats and hazards and the employment of these CBRNE task forces at combat training centers (CTCs). For the purposes of this article, the term *CBRNE* includes the full range of low- to high-yield explosive threats, encompassing the subset of critical tasks that EOD Soldiers perform—from unexploded ordnance to improvised explosive device (IED) defeat tasks.

History

In 2003, during Operation Iraqi Freedom, the Department of Defense (DOD) was directed to find, exploit, collect, and eliminate Iraqi weapons of mass destruction (WMD). However, DOD had no standing CBRNE capability with which to accomplish this strategically important mission. The 75th Field Artillery Brigade was assigned the mission, and the unit formed the core of the 75th Exploitation Task Force. But because the 75th Exploitation Task Force was merely an ad hoc solution to a strategic problem, the task force immediately faced numerous capability challenges resulting from a lack of doctrine, training, communications, organization, and equipment. Recognizing these challenges, Headquarters, Department of the Army (DA), directed the establishment of a single headquarters for worldwide CBRNE response in support of homeland defense and

regional combatant commanders. Consequently, the 20th CBRNE Command (originally named the Guardian Brigade, then the 20th Support Command) was activated on 16 October 2004 to provide a synergistic response to the dynamic, rapidly evolving, asymmetric threats that we now face.

Even before the 20th CBRNE Command reached full operational capability, the 2006 *Quadrennial Defense Review Report* further expanded its mission to serve as the headquarters for a rapidly deployable joint task force for WMD elimination. And today, the 20th CBRNE Command is a highly technical, special-purpose, expeditionary formation of more than 5,000 Soldiers and 225 civilians who are posted on 19 different installations across 16 states within the continental United States (CONUS). The 20th CBRNE Command includes 85 percent of the Regular Army CBRN and EOD units and is the only DA command with the specialized CBRNE capabilities and expertise necessary to effectively operate across the full range of CBRNE threats and hazards. These capabilities reside within the 48th Chemical Brigade; the 52d Ordnance Group (EOD); the 71st Ordnance Group (EOD); and the Chemical, Biological, Radiological, Nuclear, and Explosives Analytical and Remediation Activity (CARA).

To better reflect the complete set of current and anticipated command missions, orders, and taskings, the U.S. Army Forces Command (FORSCOM), in July 2014, approved the following mission statement: “The 20th CBRNE Command deploys to support unified land operations and performs mission command for Army and/or joint CBRN and EOD forces to achieve national CWMD [countering weapons of mass destruction], homeland defense, and defense support of civil authorities (DSCA) objectives while providing globally responsive CBRN and EOD forces to combatant commands.”¹

Within the homeland, the 20th CBRNE Command routinely engages and operates with—and in support of—joint, interagency, and other CBRNE organizations and entities. Specific missions involve EOD emergency response; very important person protection support activity; the defense CBRN response force; DCSA; defense support of civilian

law enforcement agencies (ranging from bomb disposal in civilian communities to the packaging and movement of recovered chemical warfare materiel); the ground collection task force for the national technical nuclear forensics mission, led by the Federal Bureau of Investigation; and other special missions with recall windows ranging from 4 hours to 2 weeks. In addition, 20th CBRNE Command forces are concurrently deployed in support of multiple geographic and functional commands and CARA is concurrently engaged with ongoing recovered chemical warfare material remediation missions at formerly used defense sites and remains ready to support analytical operations anytime, anywhere.

CBRNE Task Force

20th CBRNE Command formations had historically been employed as individual units based on the capabilities required at the company level or higher; however, commanders expressed interest in having a single CBRNE headquarters responsible for the integration and employment of these low-density, highly technical capabilities. Therefore, during 2013 operational planning activities for contingency operations, leaders of supported Army divisions and corps requested an integrating headquarters for all attached CBRN and EOD formations. As a result, the 20th CBRNE Command began organizing, training, and employing tailored CBRNE task forces with different CBRN and EOD capabilities to meet the full range of CBRNE hazards anticipated in the operational environment.

Strategic Guidance

An impetus for forming CBRNE task forces was also contained in multiple strategic documents. The *Army Strategic Planning Guidance–2013* states that “. . . the Army will implement a regionally aligned force concept that leverages the scalable capabilities of modular structures to provide mission-tailored forces to combatant commanders” and “. . . regional alignment will provide the combatant commander up to joint task force-capable headquarters with scalable, tailorable capabilities to shape the environment and provide contingency forces.”² And the *Quadrennial Defense Review–2014* reemphasizes the pursuit of “employing regionally-focused forces to provide additional tailored packages.”³ In addition, the *Army Strategic Planning Guidance–2014* states that, “Agile, adaptive, and integrated conventional forces, special operations forces (SOF), specialized [EOD] and CBRN forces, and missile defense provide a unique mix of scalable and tailorable capabilities across the total Army.”⁴ Furthermore, *Force 2025 and Beyond: Unified Land Operations—Win in a Complex World* indicates that the Army provides the preponderance of forces and capabilities necessary to counter WMD threats and CBRNE hazards in the land domain.⁵

A complex and unpredictable environment is a common strategic guidance theme that calls for an agile, adaptive, tailorable, and expeditionary Army. The 20th CBRNE Command, in partnership with supported maneuver forces, has thoroughly analyzed these challenges and will meet the demands of the rapidly changing strategic environment by

task-organizing and regionally aligning subordinate formations to ensure that forces are best organized, best trained, and focused on specific global threats.

Organization

The 20th CBRNE Command is proposing to reorganize and regionally align the command into three multifunctional CBRNE brigade task forces, with each task force enabled by a chemical, biological, radiological, nuclear, and explosives coordination element (CCE) that is enhanced with robust CBRNE planning and technical reachback capabilities (see Figure 1). Whether organized for training or contingency operations or as an enduring organization, this multifunctional task force structure is designed to—

- Deliver more capable and flexible, regionally focused CBRNE forces.
- Mitigate the challenges of historical ad hoc solutions to similar and anticipated future mission sets.
- Overcome current unity-of-command and unity-of-effort challenges resulting from the geographically distributed basing construct and complex mission profiles of the command.

Regional Alignment

To better focus training and preparation for regional contingencies while building the confidence of home station Army CBRN and EOD formation partners, the 20th CBRNE Command is proposing that each CBRNE brigade task force be regionally aligned with specific Army service component commands, consistent with the FORSCOM mission alignment orders for the CONUS-based corps:

- Task Force 71 (CBRNE), positioned in the western United States, is aligned to support I Corps, with a focus on the U.S. Pacific Command area of responsibility.
- Task Force 48 (CBRNE), positioned in the central United States, is aligned to support III Corps and is focused on the U.S. Central Command, U.S. Africa Command, and U.S. European Command areas of responsibility.
- Task Force 52 (CBRNE), positioned in the eastern United States, is aligned with XVIII Airborne Corps in support of its global response force mission.

Formation and Employment

For training, regionally aligned, multifunctional CBRNE task forces ensure the development of habitual team familiarity with supported forces and an understanding of likely deployed areas of operation. These task forces serve as a starting point for scaling and tailoring organizations across a range of contingency mission sets (Figures 1 and 2, pages 11 and 12) and may be further enabled with CCEs, nuclear disablement teams (NDTs), and mobile expeditionary laboratories.

CTC Rotations

During fiscal years 2014 and 2015, the 20th CBRNE Command has planned and executed nine CBRNE battalion task force rotations at the National Training Center, Fort Irwin, California, and the Joint Readiness Training Center,

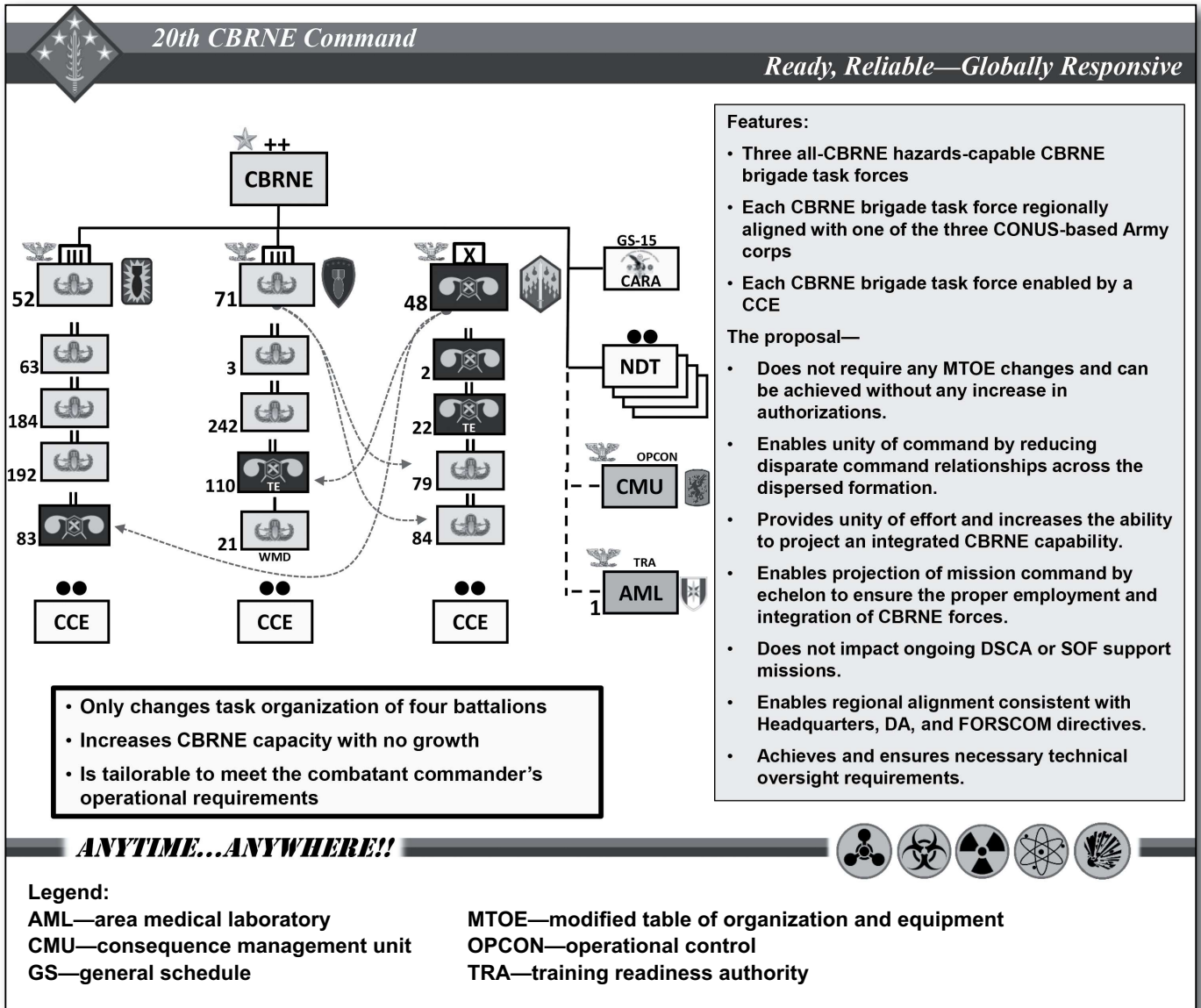

Figure 1. Proposed CBRNE brigade task force organization

Fort Polk, Louisiana. Four additional rotations are planned for fiscal year 2016.

One of the more complex CTC rotations was National Training Center 14-08, which was part of a larger 20th CBRNE Command exercise, Atropian Phoenix 14, that demonstrated the CBRNE task force concept and its role within the greater CBRNE enterprise. This distributed command post and field training exercise integrated the 20th CBRNE Command operational command post at Edgewood, Maryland, with the tactical command post of the Headquarters, 48th Chemical Brigade, Fort Hood, Texas; the Headquarters, 52d Ordnance Group (EOD), Fort Campbell, Kentucky; and CBRNE Task Force 110, Joint Base Lewis-McChord, Washington, at the National Training Center.

At the National Training Center, CBRNE Task Force 110—composed of chemical reconnaissance and

decontamination units; EOD units; chemical, biological, radiological, nuclear, and explosives response teams (CRTs); an NDT; and a heavy, mobile, expeditionary laboratory (HMEL) (Figure 3, page 13)—supported the 2d Stryker Brigade Combat Team from Joint Base Lewis-McChord. The task force conducted CBRNE operations throughout the area of responsibility to protect U.S. forces from enemy CBRNE employment, enable freedom of movement and maneuver, and support CBRNE counterforce operations by securing and exploiting hazardous sites to prevent enemy production, use, or proliferation of WMD or CBRNE material. The task force formation allowed the integration of capabilities under a single commander; otherwise, the assignment of multiple, potentially separate command and support relationships would have been required throughout the supported brigade combat team.

The CBRNE battalion task force is tailorable and scalable, providing integrated CBRNE capability with a mission command element to the supported commander.

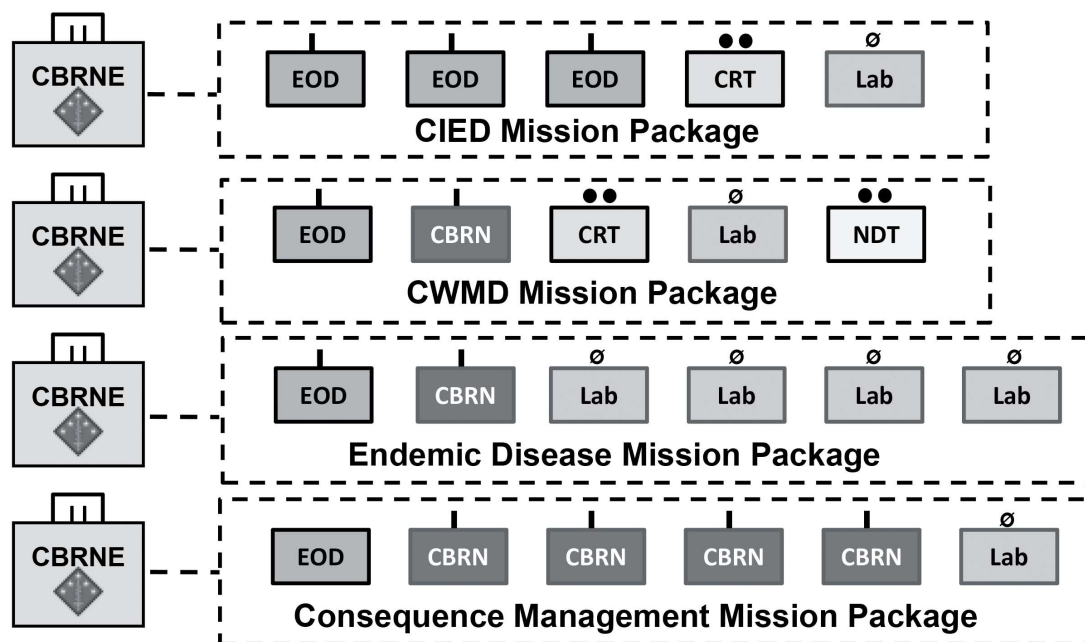

ANYTIME...ANYWHERE!!

Legend:

CIED—counter improvised explosive device

lab—laboratory



Figure 2. Potential integrated CBRNE mission packages to meet identified threats

Following Atropian Phoenix 14, the commander of CBRNE Task Force 110 summarized the impact by stating, “The exercise forced the CBRNE task force to effectively integrate with maneuver and other supporting units to conduct a coherent counter WMD and counter IED campaign. We see this as the wave of the future for our formations.” The commander of the 48th Chemical Brigade added, “Atropian Phoenix improved our ability to operate as a CBRNE task force by allowing us to train with a set of enablers—communications capabilities, technical capabilities—that we don’t have organically in a normal chemical brigade command post.” He also said that the inclusion of a CCE greatly improved his ability to command integrated CBRNE operations.

Gaps and the Way Forward

Through experiences with CTC rotations, the 20th CBRNE Command will continue to shape its supported maneuver partners’ understanding of its capabilities and better

inform the CBRNE enterprise about the best way to support maneuver commanders and to resource expeditionary activities. The CTC rotations have illuminated gaps—particularly in the areas of communication, sustainment, mobility, and protection—while establishing the foundation for tactics, techniques, and procedures for executing CBRNE operations, which must be standardized and trained throughout the Army. Some of the specific gaps involve organizational logistics; communications; mission command; technical intelligence and fusion capabilities; and the ability of subordinate forces to provide readily available, multifunctional, and modular CBRNE capabilities. The 20th CBRNE Command, in partnership with the U.S. Army Training and Doctrine Command, continues to formally capture lessons learned across the warfighting functions. The Maneuver Support Center of Excellence is currently drafting Army Techniques Publication 3-37.11, *CBRNE Task Force Operations*, to help address doctrine and training gaps.

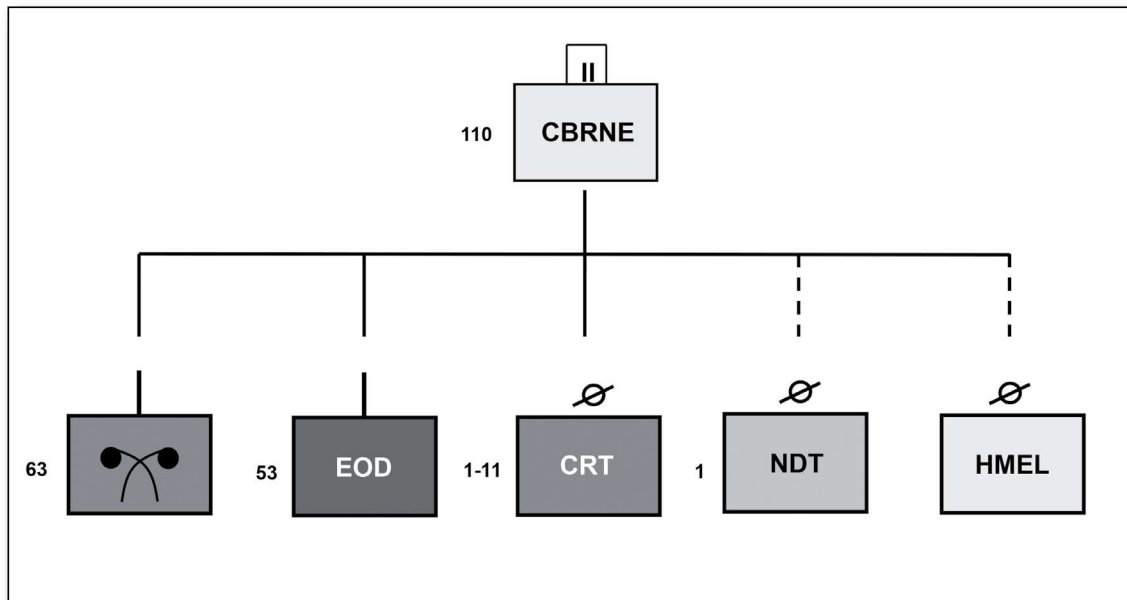

Figure 3. CBRNE Task Force 110

Conclusion

The objective of the 20th CBRNE Command is to provide the Army and the Nation with ready, reliable, and globally responsive CBRNE forces that are capable of leading and executing CBRNE-related operations and activities, anytime and anywhere. Organizing 20th CBRNE Command capabilities into regionally aligned, scaled, and tailored CBRNE task forces is an important step in meeting the Nation’s strategic guidance for this one-of-a-kind formation; and it provides our Army and our Nation with an improved solution for delivering an integrated CBRNE capacity to meet expeditionary and campaign requirements.

Endnotes:

¹“20th CBRNE Command,” briefing, National Defense Industrial Association, 27 February 2015, <<http://www.ndia.org/Divisions/Divisions/CBRN/Documents/530b%20-%20NDIA%20Briefing%20Feb%202015%20RELEASABLE.pdf>>, accessed on 24 March 2015.

²Army Strategic Planning Guidance–2013, pp. 2 and 5, <http://usarmy.vo.llnwd.net/e2/rv5_downloads/info/references/army_strategic_planning_guidance.pdf>, accessed on 23 April 2015.

³Quadrennial Defense Review–2014, DOD, 4 March 2014, <http://www.defense.gov/pubs/2014_Quadrennial_Defense_Review.pdf>, accessed on 23 April 2015.

⁴Army Strategic Planning Guidance–2014, p. 18, <<http://www.defenseinnovationmarketplace.mil/resources/ASPG2014.pdf>>, accessed on 23 April 2015.

⁵Force 2025 and Beyond: Unified Land Operations—Win in a Complex World, U.S. Army Training and Doctrine Command, October 2014, <http://www.arcic.army.mil/app_documents/TRADOC_AUSA_Force2025AndBeyond-UnifiedLandOperations-WinInAComplexWorld_07OCT2014.pdf>, accessed on 23 April 2015.

References:

20th CBRNE, Web site, <<http://www.cbrne.army.mil/>>, accessed on 24 March 2015.

Department of Defense Instruction (DODI) 3025.21, *Defense Support of Civilian Law Enforcement Agencies*, 27 February 2013.

Presidential Policy Directive (PPD) 17, *Countering Improvised Explosive Devices*, 14 June 2012.

Quadrennial Defense Review Report, DOD, 6 February 2006.

J. B. Burton is the U.S. Army Transitioning Executive Leader, Washington, D.C. He is the former commander, 20th CBRNE Command, Aberdeen Proving Ground, Maryland. He holds a master of military art and science degree from the U.S. Army Command and General Staff College, U.S. Army Combined Arms Center, Fort Leavenworth, Kansas, and a master’s degree in national security and strategic studies from the U.S. Naval War College, Newport, Rhode Island.

Colonel Burpo is the Deputy Commander for Transformation, 20th CBRNE Command. He also serves as the deputy head of the Department of Chemistry and Life Science, U.S. Military Academy–West Point, New York. He holds a master’s degree in chemical engineering from Stanford University, Stanford, California, and a doctor of science degree in bioengineering from the Massachusetts Institute of Technology.

Lieutenant Colonel Smoak (Retired) served as an Army chemical officer for 24 years. Since his retirement, he has coauthored the U.S. Department of Homeland Security Domestic Preparedness Program, facilitated national-level crisis management seminars in five of the former Soviet republics, served as the chief CBRN technical officer in support of the Guardian Program, and supported the 20th CBRNE Command during exercises from Jordan to South Korea.